

# **RICHARD WESTERN**

**THE COMPANY FOR ALL SEASONS**



**PRICE LIST 2012**

ISSUE 1

## COMPANY BACKGROUND AND OBJECTIVES

**RICHARD  
WESTERN**

Since the sixties Richard Western Ltd have been developing their range of equipment to suit the changing needs of modern agriculture. Our objective is to manufacture high quality machinery with modern functional designs that will deliver reliable and efficient performance. Please feel free to discuss your individual requirements with us.



## INDEX

	page no.
Suffolk Trailers	5-8
Rootcrop Trailers	9-10
Wellington Trailers	11-12
Bale and Pallet Trailers	13-14
Low Loader Trailers	15-16
Agricultural Dumper Trailers	17-18
Manure Spreaders	19-26
Vacuum Tankers	27-30
Forage Box Feeders	31-32
Fieldrunners	33-34
Transfer Wagon	35-36
Drill Filler/Meal and Pellet Feeder	37-38
Wheel and Axle options	39-40
Warranty, Terms and Conditions	42



**DELILAH SPREADER**

D10 Delilah manure spreader on 650/75R32 tyres. Options include hydraulic slurry door.



### **SUFFOLK TRAILER**

SF14 Suffolk Trailer. Options include: Height adjustable sprung drawbar, hydraulic tailgate with rubber seal and auto lock, grain chute, mudguards and mud flaps, 560/60R22.5 Flotation radial tyres, Roll over sheet.

## SUFFOLK TRAILERS

HEAVY DUTY MONOCOQUE TRAILERS WITH A NATIONWIDE REPUTATION FOR STRENGTH AND DURABILITY. AVAILABLE IN 10, 11, 12, 14, 16, 18 & 20 TONNE MODELS.



The Suffolk trailer has a unique chassis beam construction for maximum strength and durability. It also has shock absorption pads to eliminate noise vibration and steel hydraulic pipes are mounted along the centre of the chassis. The Suffolk trailer uses a modern design to optimise strength to weight ratio. Features include: Unique monocoque construction of 4mm floor and 3mm sides, tapered body, drain holes, skid hanger, inspection ladder and rope hooks. A choice of sprung axles using commercial mono leaf road springs and axle towing arms with replaceable bushes or rocking beam axles using heavy duty construction on large diameter pivot pins with replaceable bushes. Hydraulic brakes are standard.

## SUFFOLK TRAILERS

SUFFOLK TRAILERS	SF10	SF11	SF12	SF14	SF16	SF18	SF20
Overall Length	6.42 m	6.68 m	7.02 m	7.48 m	8.41 m	8.41 m	9.00 m
Width Front	2.13 m	2.13 m	2.13 m	2.13 m	2.13 m	2.13 m	2.13 m
Width Rear	2.27 m	2.27 m	2.27 m	2.27 m	2.27 m	2.27 m	2.27 m
Body Height	1.22 m	1.32 m	1.37 m	1.37 m	1.37 m	1.52 m	1.52 m
Body Length	4.77 m	5.02 m	5.39 m	5.85 m	6.78 m	6.78 m	7.40 m
Top Rail Height	2.35 m	2.54 m	2.60 m	2.60 m	2.60 m	2.75 m	2.76 m
Tipped Height	5.63 m	5.96 m	6.30 m	6.68 m	7.44 m	7.52 m	8.06 m
Silage Top Rail Height	3.25 m	3.44 m	3.50 m	3.50 m	3.50 m	3.65 m	3.66 m
Tipped Silage Height	6.10 m	6.42 m	6.75 m	7.13 m	7.99 m	8.67 m	9.20 m
Tip Clearance	0.77 m	0.85 m	0.85 m	0.85 m	0.85 m	0.85 m	0.85 m
Platform Height	1.14 m	1.24 m	1.24 m	1.24 m	1.24 m	1.24 m	1.24 m
Grain Capacity	13.21 cu.m	15.04 cu.m	16.76 cu.m	18.19 cu.m	21.09 cu.m	23.39 cu.m	25.53 cu.m
Silage Capacity	23.00 cu.m	25.30 cu.m	27.77 cu.m	30.14 cu.m	34.94 cu.m	37.25 cu.m	40.65 cu.m
Number Of Axles	2	2	2	2	2	2	3
Axle Track	2.00 m	2.00 m	2.00 m	2.00 m	2.00 m	2.00 m	2.00 m
Tyres	12.5 x 15	15 x 22.5 - 18PR Rem	15 x 22.5 - 18PR Rem	15 x 22.5 - 18PR Rem	15 x 22.5 - 18PR Rem	15 x 22.5 - 18PR Rem	15 x 22.5 - 18PR Rem
Tare Weight	2790 kg	3260 kg	3510 kg	4075 kg	4850 kg	5210 kg	5460 kg

## SUFFOLK TRAILERS



### STANDARD FEATURES

- Monocoque tapered body 4mm floor, 3mm sides
- LED Road lights complete with protective covers
- 2.0 metre axle track
- Hydraulic brakes
- Inspection ladder
- Body prop
- Chassis shock absorption pads

### OPTIONAL EQUIPMENT

- Rocking beam axles in lieu of springs £455
- Sprung draw bar £1,227
- Swivel drawbar eye £162
- Double acting hydraulic tailgate £1,462
- Grain chute £162
- Grain sock £162
- Anti-jack knife system £964
- Perspex Window £162
- Full width grill with fold down grain panel £487
- Arched front window with perspex panel £595
- Mesh window £162
- Flashing beacon kit £196
- Hydraulic jack £379
- Screw jack £379
- Rear drawbar c/w brakes and electrics £596
- Roll over sheet £1,906
- Fitted bulker sheet £541
- Sheet rack £379
- 6mm floor 4mm sides £1,082
- Metal mudguards and mudflaps £601
- Inside steps £162
- For wheel and axle options see page 39

for details of LX and HS specifications see page 41

## SUFFOLK TRAILERS

### SUFFOLK TRAILER PRICES

		LX	HS
<b>SF10</b> - 16'0" x 7'0"/7'6" x 4'0"			
12.5 x 15 - 14PR Flotation tyres, 6 stud axles	Std		
Standard grain trailer		£8,761	£9,860
Front or side load silage - Automatic up and over door		£10,973	£12,073
Front or side load silage - Hydraulic up and over door		£11,797	£12,896
<b>SF11</b> - 16'10" x 7'0"/7'6" x 4'4"			
15 x 22.5 - 18PR Rem 8 stud axles	Std		
Standard grain trailer		£10,247	£10,767
Front or side load silage - Automatic up and over door		£12,456	£12,976
Front or side load silage - Hydraulic up and over door		£13,323	£13,843
<b>SF12</b> - 18'0" x 7'0"/7'6" x 4'6"			
15 x 22.5 - 18PR Rem 8 stud axles	Std		
Standard grain trailer		£11,373	£12,527
Front or side load silage - Automatic up and over door		£13,648	£14,801
Front or side load silage - Hydraulic up and over door		£14,513	£15,667
<b>SF14</b> - 19'6" x 7'0"/7'6" x 4'6"			
15 x 22.5 - 18PR Rem 10 stud axles	Std		
Standard grain trailer		£12,997	£14,557
Front or side load silage - Hydraulic up and over door		£16,518	£18,078
<b>SF16</b> - 22'6" x 7'0"/7'6" x 4'6"			
15 x 22.5 - 18PR Rem 10 stud axles	Std		
Standard grain trailer		£15,521	£16,154
Front or side load silage - Hydraulic up and over door		£18,559	£19,404
<b>SF18</b> - 22'6" x 7'0"/7'6" x 5'0"			
15 x 22.5 - 18PR Rem 10 stud commercial axles	Std		
Standard grain trailer			£16,996
Front or side load silage - Hydraulic up and over door			£20,687
<b>SF20</b> - 24'6" x 7'0"/7'6" x 5'0"			
18 x 22.5 - 18PR Rem 10 stud axles Tri-axle	Std		
Standard grain trailer			£23,736
Front or side load silage - Hydraulic up and over door			£27,631

## ROOTCROP TRAILERS

MONOCOQUE BODY LOW-LINE TRAILERS.  
AVAILABLE IN 11, 12, 14, 16 & 18 TONNE MODELS.



The Suffolk Rootcrop trailer is a low line trailer to facilitate damage free root-crop harvesting. Using the Suffolk design features Rootcrop trailers have a lower side height and a longer body. All Rootcrop models are standard on commercial mono-leaf springs, 1.83 metre axle track and 15 x 22.5 tyres.

### STANDARD FEATURES

- Monocoque tapered body  
4mm floor, 3mm sides
- LED road lights complete with protective covers
- 1.83 metre axle track
- Hydraulic brakes
- Inspection ladder
- Chassis shock absorption pads
- Double acting hydraulic tailgate
- Full width grill with a fold down grain panel
- Body prop
- Use Suffolk Trailer options
- For wheel and axle options see page 39

for details of LX and HS specifications see page 41

## ROOTCROP TRAILERS

ROOTCROP TRAILERS	RC11	RC12	RC14	RC16	RC18
Price Standard trailer	£12,782	£14,048	£16,518	£18,576	
LX (50% braking @ 60kph)	£13,302	£15,203			
HS (c/w commercial axles)	£14,862	£16,128	£17,829	£19,176	£22,976
Overall Length	7.02 m	7.48 m	8.41 m	9.02 m	10.61 m
Width Front	2.13 m	2.13 m	2.13 m	2.13 m	2.13 m
Width Rear	2.27 m	2.27 m	2.27 m	2.27 m	2.27 m
Body Height	1.15 m	1.15 m	1.15 m	1.15 m	1.15 m
Body Length	5.39 m	5.85 m	6.78 m	7.40 m	8.40 m
Top Rail Height	2.24 m	2.24 m	2.24 m	2.24 m	2.24 m
Tipped Height	6.23 m	6.47 m	7.36 m	7.89 m	9.00 m
Silage Top Rail Height	3.14 m	3.14 m	3.14 m	3.14 m	3.14 m
Tipped Silage Height	7.25 m	7.63 m	8.38 m	8.90 m	9.72 m
Tip Clearance	0.85 m	0.85 m	0.85 m	0.85 m	0.85 m
Platform Height	1.24 m	1.24 m	1.24 m	1.24 m	1.24 m
Grain Capacity	13.64 cu.m	14.80 cu.m	17.15 cu.m	18.72 cu.m	21.25 cu.m
Silage Capacity	24.31 cu.m	26.34 cu.m	30.58 cu.m	33.37 cu.m	37.88 cu.m
Number Of Axles	2	2	2	2	2
Axle Track	1.83 m	1.83 m	1.83 m	1.83 m	1.83 m
Tyres	15 x 22.5 - 18PR Rem	15 x 22.5 - 18PR Rem	15 x 22.5 - 18PR Rem	15 x 22.5 - 18PR Rem	15 x 22.5 - 18PR Rem
Tare Weight	3910 kg	4475 kg	5250 kg	5860 kg	6500kg

## WELLINGTON TRAILERS

MONOCOQUE BODY 60° TIPPING TRAILERS.  
AVAILABLE IN 14, 16, 18, 20 & 24 TONNE MODELS.

The Wellington Trailer is a heavy duty monocoque trailer built to the highest specification using commercial axles and suspension units. The Wellington range features a 60degree tipping angle and a heavy duty double acting hydraulic levelling tailgate with 9'0" clearance, making it the ideal choice for Beet heaping.



### STANDARD FEATURES

- Monocoque tapered body  
4mm floor, 4mm sides
- 60° tipping body
- Anti-corrosive rams
- 9' clearance double acting hydraulic levelling tailgate
- Inspection ladder
- 10 stud commercial axles with 420mm x 180mm brakes
- Hydraulic brakes
- Lights in heavy duty bracket
- Heavy duty sprung drawbar
- Steel mudguards with mudflaps
- Full width grill with mesh & perspex
- Rear tow out points
- Heavy duty 8mm steel chassis
- Cast steel spring hangers

### OPTIONAL EQUIPMENT

- Use Suffolk Trailer options
- For wheel and axle options see page 39

## WELLINGTON TRAILERS

WELLINGTON TRAILERS	SWT14	SWT16	SWT18	SWT20	SWT24
Price Std Trailer	£20,579	£22,746	£23,829	£33,848	£37,650
Silage Trailer	£24,100	£26,375	£27,457	£38,182	£42,415
Overall Length	7.48 m	8.39 m	8.41 m	9.02 m	10.16 m
Width Front	2.13 m	2.13 m	2.13 m	2.13 m	2.13 m
Width Rear	2.27 m	2.27 m	2.27 m	2.27 m	2.27 m
Body Height	1.52 m	1.37 m	1.52 m	1.52 m	1.52 m
Body Length	5.87 m	6.78 m	6.78 m	7.40 m	8.40 m
Top Rail Height	2.84 m	2.67 m	2.84 m	2.84 m	3.34 m
Tipped Height	7.12 m	7.83 m	7.91 m	8.52 m	9.55 m
Silage Top Rail Height	3.74 m	3.57 m	3.74 m	2.74 m	4.24 m
Tipped Silage Height	7.97 m	8.05 m	8.82 m	9.26 m	10.35 m
Tip Clearance	0.93 m	0.93 m	0.93 m	0.93 m	0.93 m
Platform Height	1.31 m	1.31 m	1.31 m	1.31 m	1.31 m
Grain Capacity	20.25 cu.m	21.09 cu.m	23.39 cu.m	25.53 cu.m	28.98 cu.m
Silage Capacity	32.24 cu.m	34.94 cu.m	37.25 cu.m	40.65 cu.m	46.14 cu.m
Number Of Axles	2	2	2	3	3
Axle Track	2.00 m	2.00 m	2.00 m	2.00 m	2.00 m
Tyres	18 x 22.5 18PR Rem	18 x 22.5 18PR Rem	18 x 22.5 18PR Rem	18 x 22.5 18PR Rem	18 x 22.5 18PR Rem
Tare Weight	4950 kg	5350 kg	5450 kg	6660 kg	7500 kg

## BALE AND PALLET TRAILERS

A RANGE OF TANDEM AXLE FLATBED TRAILERS.  
AVAILABLE IN 10, 12 AND 14 TONNE MODELS.



### OPTIONAL EQUIPMENT

- Sprung draw bar (adjustable height) £1,227
- Durbar floor (per trailer foot) £26
- Additional length (per trailer foot) £226
- Bale ladders £379
- Steering axle £2,159
- Raised edges £379
- Drop side walkway £720
- Hydraulic box pusher £839
- For wheel and axle options see page 39

The Western Bale and Pallet Trailer range has a chassis constructed from 6mm formed steel section with a 4mm steel plate platform.

### STANDARD FEATURES

- 4mm steel floor
- 2' headboard
- Hydraulic brakes
- LED road lights



for details of LX and HS specifications see page 41

## BALE AND PALLET TRAILERS

BALE & PALLET TRAILERS	BTTA10/25	BTTA12/25	BTTA12/30	BTTA14/32
Price	£8,337	£9,622	£10,100	£10,985
LX (50% Braking @ 60kph)	£9,622	£10,143	£10,620	
HS (c/w commercial axles)	£11,521	£11,703	£12,180	£12,545
Carrying Capacity	10 tonnes	12 tonnes	12 tonnes	14 tonnes
Body Length (B)	7.32m	7.32m	9.14m	9.75m
Width (A)	2.40m	2.40m	2.40m	2.40m
Platform Height (D)	1.12m	1.17m	1.17m	1.17m
Headboard Height	0.60m	0.60m	0.60m	0.60m
Bale Ladder Height (C)	1.80m	1.80m	1.80m	1.80m
Axle To Rear (E)	2.44m	2.44m	2.75m	2.86m
Axle Track	1.70m	1.83m	1.83m	1.83m
Number Of Axles	2	2	2	2
Tyres Size	12.5 x 15	15 x 22.5	15 x 22.5 18PR Rem.	15 x 22.5 18PR Rem.
Unladen Weight	1750kg	1850kg	1900kg	2000kg

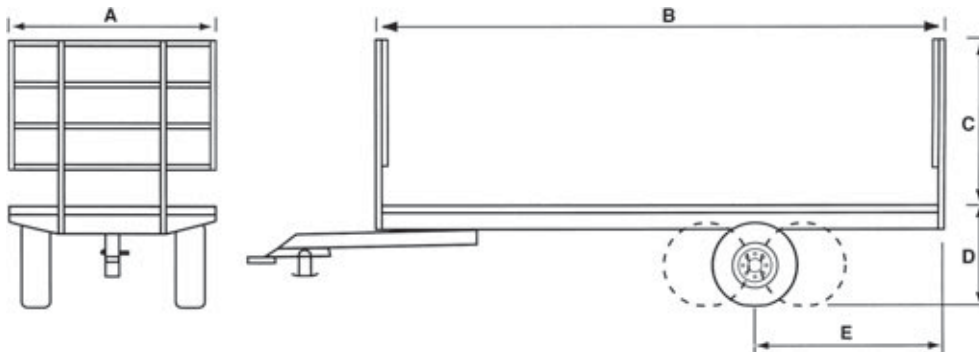

## LOW LOADER TRAILERS

A RANGE OF DROP BED LOW LOADERS FOR TRANSPORTING IMPLEMENTS.  
AVAILABLE IN 6 & 7.5 TONNE MODELS.



### STANDARD FEATURES

- 4.5mm steel floor
- Hydraulic brakes
- Loading chocks
- Lights

The Western Low Loader Trailers are designed so that the bed of the trailer lowers down to the ground by pivoting the rear axle. The front of the trailer being raised and lowered by means of the tractor pick-up hitch. The rear axle of the trailer is returned to transport position by a hydraulic ram powered by the tractor hydraulics. Then locked into position by two pins. The whole operation takes only a few seconds to complete and no tools are required.

No load is carried on the hydraulics while in transit. The trailers are suitable for moving all types of farm machines including smaller crawler tractors.

### OPTIONAL EQUIPMENT

- Durbar floor (per trailer foot) £26
- Steering axle £2,159
- For wheel and axle options see page 39

## LOW LOADER TRAILERS

LOW LOADER TRAILERS	LL6	LL7.5
Price	£7,257	£7,972
Chassis Size	177.8 x 152.4 mm	203.2 x 152.4 mm
Platform Length	5.48 m	6.40 m
Width	2.40 m	2.40 m
Load Carrying Capacity	6 Tonnes	7.5 Tonnes
Number Of Axles	1	1
Axle Track	2.00 m	2.00 m
Tyres	12.5 x 15 14PR	15 x 22.5 18PR Rem
Tare Weight	1250 kg	1500 kg



## AGRICULTURAL DUMPER TRAILERS

LARGE CAPACITY  
DUMPER  
TRAILERS FOR  
AGRICULTURAL  
AND GENERAL USE.  
AVAILABLE IN  
8, 10, 12, 14 & 16  
TONNE MODELS.

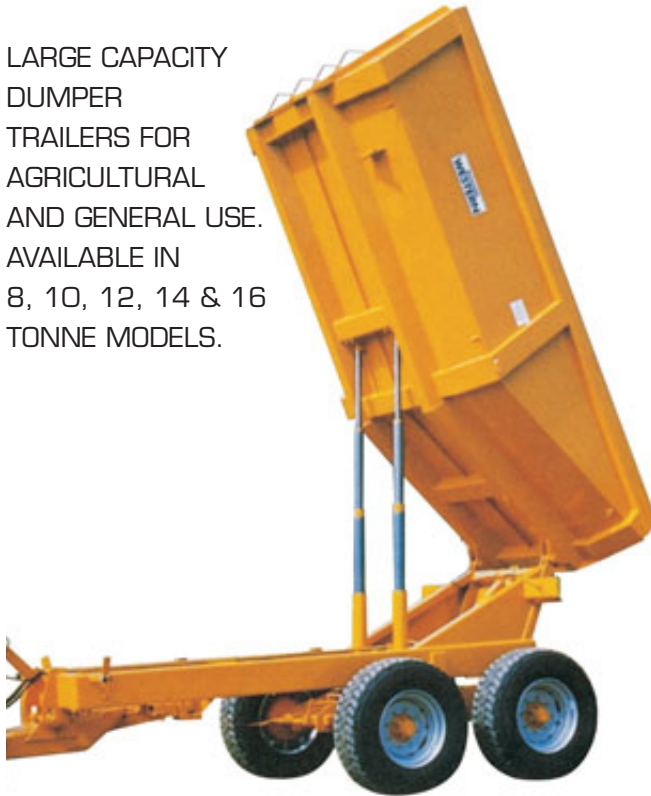

The Western Dumper Trailer range is manufactured with a 4mm floor and 3mm sides with 6mm and 4mm option.

Available in single and tandem axle models.

### STANDARD FEATURES

- 4mm steel floor, 3mm sides
- Inspection ladder
- LED road lights with protective covers
- Hydraulic brakes
- Rocking beam (tandem axle only)
- Sprung drawbar - 12-16 tonne
- Anti-jack knife - 12-16 tonne

### OPTIONAL EQUIPMENT

- Grain conversion kit 8-10 tonne £1,263
- (includes tailgate) 12-16 tonne £1,480
- Grain chute (including pipe fitting) £226
- Slurry extension £704
- 6mm floor and 4mm sides £1,082
- Anti-jack knife - 10 tonne only £964
- Mechanical automatic tailgate £1,062
- Also see Suffolk Trailer options page 7
- For wheel and axle options see page 39

for details of LX and HS specifications see page 41

## AGRICULTURAL DUMPER TRAILERS

DUMPER TRAILERS	DU8	DUTA8	DUTA10	DUTA12	DUTA14	DUTA16
Price	£8,123	£8,882	£10,832	£15,164	£19,388	£22,442
LX (50% Braking @ 60kph)		£9,982	£11,353	£16,318		
HS (c/w commercial axles)		£12,065	£12,913	£17,244	£20,169	£23,287
Length (L)	6.12 m	6.12 m	6.73 m	7.07 m	7.75 m	7.75 m
Width	2.53 m	2.53 m	2.53 m	2.53 m	2.53 m	2.53 m
Body Length (A)	4.73 m	4.73 m	5.37 m	5.87 m	6.57 m	6.57 m
Body Height (H)	1.12 m	1.12 m	1.40 m	1.40 m	1.49 m	1.69 m
Top Rail Height (B)	2.29 m	2.26 m	2.74 m	2.74 m	2.97 m	3.17 m
Tipped Height (M)	6.24 m	6.22 m	7.19 m	7.68 m	8.52 m	8.60 m
Capacity	9.72 cu.m	9.72 cu.m	12.80 cu.m	14.45 cu.m	17.45 cu.m	19.92 cu.m
Number Of Axles	1	2	2	2	2	2
Axle Track	2.00 m	2.00 m	2.00 m	2.00 m	2.00 m	2.00 m
Tyres	15 x 22.5 18PR Rem.	12.5 x 15 14PR	15 x 22.5 18PR Rem.	15 x 22.5 18PR Rem.	20.5 x 22.5 Kargo Rem.	560/60 x 22.5 Flotation
Tare Weight	3000kg	3050kg	3550kg	3750kg	3900kg	4000kg

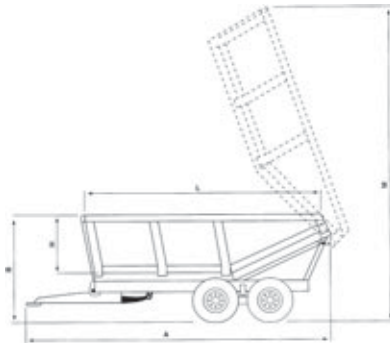

## DELILAH MANURE SPREADERS

TWIN VERTICAL BEATER, REAR DISCHARGE MANURE SPREADER  
AVAILABLE IN 8, 10, 12 AND 18 TONNE MODELS



## DELILAH MANURE SPREADERS

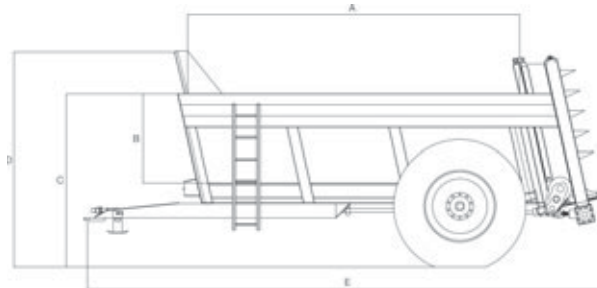

The Delilah manure spreader is a heavy duty spreader designed to handle all types of manures - FYM, semi-solid, poultry litter, industrial sludges, waste products etc. The unique design rotor and blade pattern allows you to spread all types of manures without the trouble and fuss of changing spreader decks.

The Delilah is designed to meet the demands of modern agriculture. The robust body construction means the Delilah is built to handle the toughest conditions during loading. The large diameter spreader rotors means that the Delilah gives you maximum shredding and the four heavy duty floor chains with rugged drive shaft means you get high spreading speeds.



## DELILAH MANURE SPREADERS

### STANDARD FEATURES

- Wide angle PTO with shearbolt protection
- 15 Tonne hydraulically braked axle
- Robust construction 6mm floor & 4mm sides
- One piece rotor gearbox unit
- Variable speed hydraulic floor drive, pressure protected with reverse function
- 4 Heavy duty bed chains (100 tonne breaking strain)
- 10mm thick sectional spiral auger beaters for maximum shredding and spreading up to 16 metres wide
- 60mm floor drive shaft with self-cleaning chain sprockets
- Reversible hardened rotor blades with break back stops
- 1000rpm PTO speed

### OPTIONAL EQUIPMENT

- |   |        |
|---|--------|
| • Hydraulic slurry door   | £2,153 |
| • Composting doors  | £646   |
| • Power folding lights  | £347   |
| • Sprung drawbar  | £1,227 |
| • Rear drawbar c/w brakes and electrics   | £596   |
| • Greedy boards   | £1,100 |
| • Electronic bed speed control  | £496   |
| • Radar ground speed control kit  | £1,870 |
| • Weighing and recording equipment  | £6,475 |
| • Horizontal beater and spinning disc spreading kit in lieu of vertical beaters | £5,457 |



## DELILAH MANURE SPREADERS

DELILAH SPREADERS	D8	D10	D12	D18T
Price	£22,307	£23,731	£27,017	£44,881
Body Length	3.52 m	4.64 m	5.64 m	6.61 m
Body Depth	1.24 m	1.24 m	1.24 m	1.24 m
Body Width	1.50 m	1.50 m	1.50 m	1.50 m
Loading Height	2.40 m	2.40 m	2.55 m	2.65 m
Overall Height	3.09 m	3.17 m	3.32 m	3.30 m
Overall Width	2.80 m	2.91 m	3.06 m	3.06 m
Overall Length	6.33 m	7.31 m	8.31 m	10.0 m
Capacity	7.15 cu.m	9.18 cu.m	11.22 cu.m	18.30 cu.m
Number Of Axles	1	1	1	2
Axle Track	2.30 m	2.30 m	2.30 m	2.30 m
Tyres	18.4 x 34	650/75 x 32	650/75 x 32	650/75 x 32 + B20
Tare Weight	4895 kg	5530 kg	5825 kg	6950 kg

## FBS MANURE SPREADERS

TWIN VERTICAL BEATER, REAR DISCHARGE MANURE SPREADER  
AVAILABLE IN 12, 16 AND 20 TONNE MODELS

The FBS manure spreader is a large capacity spreader designed to handle all types of manures - FYM, semi-solid, poultry litter, industrial sludges, waste products etc. The unique rotor design and blade pattern allows you to spread all types of manures without the trouble and fuss of changing spreader decks and the large cubic capacity of the FBS is particularly suited to low density manures.



## FBS MANURE SPREADERS

FBS SPREADERS	FBS12	FBS16	FBS20
Price	£32,330	£40,397	£48,344
Body Length	4.74 m	5.39 m	7.80 m
Body Depth	1.09 m	1.09 m	1.20 m
Body Width	2.00 m	2.00 m	2.00 m
Loading Height	2.65 m	2.66 m	2.71 m
Overall Height	3.63 m	3.63 m	3.63 m
Overall Width	2.58 m	2.58 m	2.58 m
Overall Length	7.77 m	8.52 m	10.60 m
Capacity	12.00 cu.m	14.00 cu.m	19.00 cu.m
Number Of Axles	2	2	2
Axle Track	2.00 m	2.00 m	2.00 m
Tyres	550/60 x 22.5	560/60 x 22.5	560/60 x 22.5
Tare Weight	5500 kg	6000 kg	6500 kg

### STANDARD FEATURES

- Wide angle PTO with shearbolt protection
- 22 Tonne hydraulically braked axles
- Robust construction 6mm floor & 4mm sides
- One piece rotor gearbox unit
- Variable speed hydraulic floor drive, pressure protected with reverse function
- 4 Heavy duty bed chains (100 tonne breaking strain)

- 10mm thick sectional spiral auger beaters for maximum shredding and spreading up to 20 metres wide
- 60mm floor drive shaft with self-cleaning chain sprockets
- Reversible hardened rotor blades with break back stops

### OPTIONAL EQUIPMENT

- Use Delilah spreader options



## SDS MANURE SPREADERS

SIDE DISCHARGE SLURRY / MANURE SPREADER  
AVAILABLE IN 1600, 2000 AND 2400 GALLON MODELS



The SDS spreader range is designed to handle semi-solids, sludges and slurries. The heavy duty central auger with aggressive spaced paddles prevents load bridging and ensures a constant flow to the spreading rotor.

The massive 1.5 metre wide spreading rotor means the SDS makes easy work of solid and semi-solid manures.

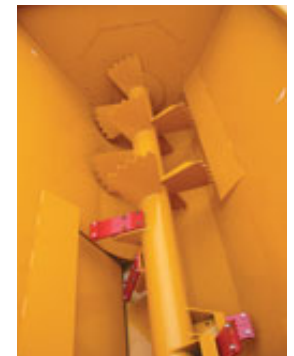

## SDS MANURE SPREADERS

SDS SPREADERS	SDS16	SDS20	SDS24	SDS24T
Price	£19,265	£22,047	£24,262	£25,111
Body Length	3.73 m	4.55 m	5.55 m	5.55 m
Body Width	2.10 m	2.10 m	2.10 m	2.10 m
Loading Height	2.45 m	2.45 m	2.53 m	2.52 m
Overall Length	5.95 m	6.75 m	7.74 m	7.74 m
Overall Width	2.60 m	2.60 m	2.76 m	2.59 m
Capacity	7264 lt	9080 lt	10896 lt	10896 lt
Number Of Axles	1	1	1	2
Axle Track	2.00 m	2.00 m	2.00 m	2.00 m
Tyres	23.1 x 26	23.1 x 26	650/75 x32	560/60 x 22.5
Tare Weight	4500 kg	5125 kg	5750 kg	6250 kg

### STANDARD FEATURES

- 1.5 metre wide spreading rotor area
- Reversible face plates on rotor and centre auger
- Double acting hydraulic side door
- Spring steel auger discharge paddle
- Heavy duty construction with 6mm body panels
- Up to 16 metres wide even spread
- RTA lights
- 15 tonne hydraulically braked axle
- 3 stage reduction gearing

### OPTIONAL EQUIPMENT

- Power flow auger £2,865



## ST VACUUM TANKERS

VACUUM FILL, PRESSURE DISCHARGE SLURRY TANKERS  
AVAILABLE IN SINGLE & TANDEM AXLE FROM 1500 TO 4000 GALLONS.



Richard Western slurry tankers are built using 6mm high quality steel mounted on a rugged design chassis. Internal baffles are fitted to reduce liquid movement during transport.

### OPTIONAL EQUIPMENT

● Side fill point	£292	● Full length mudguard and hose tray	£1,017
● Self loading arm	£2,663	● 2.5 metre dribble bar	£737
● Full length sight tube	£184	● Garda pump	£3,458
● Hydraulic top fill	£931	● Rain cannon with hydraulic swivel	£1,183
● Flashing beacon	£196	● Side mounted storage box	£515
● Side jetter	£272	● Hydraulic vacuum pump	£1,509
● Suction hose per metre	£44	● In tank agitator	£1,515
● Sprung drawbar	£1,227	● Silencer and oil collector	£810
● Full opening rear door	£476	● Air cooled pump with grit filters	£5,295
		● Grit filters for vacuum pump	£785

for details of LX and HS specifications see page 41

## ST VACUUM TANKERS

VACUUM TANKERS	ST15	ST20	ST25	ST30	ST35	ST20LP	ST25LP
Price	£8,774	£13,965	£16,139	£18,955		£13,965	£16,139
LX (50% Braking @ 60kph)		£14,485	£17,294				
HS (c/w commercial axles)		£16,045	£18,219	£20,126	£22,297		
Tank Length	3.50 m	5.00 m	5.00 m	5.20 m	6.12 m	3.50 m	4.37 m
Overall Length	5.90 m	7.95 m	7.99 m	8.10 m	8.90 m	6.44 m	7.11 m
Overall Width	2.40 m	2.40 m	2.40 m	2.40 m	2.40 m	2.90 m	2.90 m
Height	2.55 m	2.91 m	3.06 m	3.23 m	3.23 m	3.26 m	3.30 m
Tank Diameter	1.52 m	1.52 m	1.68 m	1.83 m	1.83 m	1.83 m	1.83 m
Capacity	6810 lt	9080 lt	11350 lt	13620 lt	15900 lt	9090 lt	11350 lt
Pump Speed	8000 lt/min	10000 lt/min	10000 lt/min	12000 lt/min	12000 lt/min	8000 lt/min	10000 lt/min
Number Of Axles	1	2	2	2	2	1	1
Axle Track	2.00 m	2.00 m	2.00 m	2.00 m	2.00 m	2.00 m	2.00 m
Tyres	15 x 22.5 - 18PR Rem	15 x 22.5 - 18PR Rem	15 x 22.5 - 18PR Rem	15 x 22.5 - 18PR Rem	15 x 22.5 - 18PR Rem	28.1 x 26	28.1 x 26
Tare Weight	3250 kg	4000 kg	4250 kg	4500 kg	5250 kg	4000 kg	4250 kg

### STANDARD FEATURES

- 6mm rolled steel tank
- Rear hydraulic gate valve
- 4.5m suction hose
- LED Lights with protective covers
- Hydraulic brakes
- Sight glass front and rear
- Blank side fill point



## STC VACUUM TANKERS

A RANGE OF TANDEM AXLE VACUUM TANKERS FROM 2500 TO 4000 GALLON CAPACITY DESIGNED TO CARRY INJECTORS AND APPLICATION EQUIPMENT.



The STC range of tandem axle vacuum tankers have been designed to carry application equipment.

The extended chassis continues to the rear of the tanker and a large carrier plate with four point mounting brackets to carry injector, trailing shoe or dribble bar applicators.

### OPTIONAL EQUIPMENT

- |   |         |
|---|---------|
| ● Hydraulic sliding axle unit                                   | £1,345  |
| ● Injector linkage c/w hydraulic lift and rake adjustment       | £2,385  |
| ● 6m Grassland injector, hydraulic folding c/w macerator pump   | £22,850 |
| ● Macerator pump  | £3,596  |
| ● Electro hydraulic control box and valve block for 6m injector | £4,485  |

for details of LX and HS specifications see page 41

## STC VACUUM TANKERS

VACUUM TANKERS	STC25	STC30	STC35	STC40
Price	£23,406	£27,542	£29,323	£32,722
Tank Length	4.37 m	5.20 m	6.00 m	7.00 m
Overall Length	7.03 m	8.06 m	9.09 m	10.12 m
Overall Width	3.00 m	3.00 m	3.00 m	3.00 m
Height	3.41 m	3.41 m	3.48 m	3.55 m
Tank Diameter	1.83 m	1.83 m	1.83 m	1.83 m
Capacity	11350 lt	13620 lt	15900 lt	18181 lt
Pump Speed	12000 lt/min	12000 lt/min	12000 lt/min	12000 lt/min
Number Of Axles	2	2	2	2
Axle Track	2.20 m	2.20 m	2.20 m	2.20 m
Tyres	560/60 x 22.5	620/55 x 26.5	620/55 x 26.5	710/50 x 26.5
Tare Weight	5100 kg	5500 kg	5700 kg	6000 kg

### STANDARD FEATURES

- All features included on ST range
- Commercial axles with 420mm x 180mm brakes
- Wide axle spread to carry oversize tyres
- Sprung drawbar
- Injector ready
- Full length hose tray
- Mudguards and mud flaps
- LED Side marker lights
- Wide angled PTO shaft
- Full length sight tube
- Stone trap



Self loading arm with pick up trolley and shut off valves minimises filling time

## FORAGE BOX FEEDERS

A WELL TRIED, PROVEN, FAST, EFFICIENT AND RELIABLE FEEDER.  
MODELS AVAILABLE FW8, FW10, FW12, FW15, FW20, FW25 & FW30.



### STANDARD FEATURES

- Low front panel for excellent visibility
- 3 horizontal beaters
- Cleated rubber belt cross conveyor
- Heavy duty chain and slat floor
- Top hinged rear door
- Robust chassis and body construction
- Hydraulic brakes
- Hydraulic floor
- PTO driven beaters
- Cross conveyor rear discharge option

Front discharge forage box feeder fitted with 3 horizontal beater bars. Mechanically driven beaters and two way cross conveyor.

## FORAGE BOX FEEDERS

FEEDERS	FW8	FW10	FW12	FW15	FW20	FW25	FW30
Price	£13,802	£14,773	£18,284	£23,656	£28,433	£31,465	£34,119
Feeder Length (A)	3.38 m	4.21 m	5.44 m	5.66 m	6.00 m	6.00 m	7.00 m
Feeder Width	1.90 m	1.90 m	1.90 m	2.00 m	2.10 m	2.10 m	2.10 m
Body Height (B)	1.28 m	1.28 m	1.28 m	1.30 m	1.69 m	1.66 m	2.03 m
Overall Height (C)	2.69 m	2.69 m	2.80 m	2.91 m	3.04 m	3.52 m	3.58 m
Overall Length (D)	5.91 m	6.74 m	8.24 m	8.46 m	8.75 m	8.75 m	10.04 m
Overall Width	2.25 m	2.25 m	2.33 m	2.46 m	2.52 m	2.44 m	2.52 m
Discharge Height (E)	1.08 m	1.08 m	1.19 m	1.34 m	1.34 m	1.26 m	1.27 m
Number Of Axles	1	1	1	2	2	2	2
Axle Track	1.70 m	1.70 m	1.83 m	1.83 m	1.83 m	1.83 m	1.83 m
Tyres	12.5 x 15.3	12.5 x 15.3	435/60 x 19.5	435/60 x 19.5	435/60 x 19.5	435/60 x 19.5	435/60 x 19.5
Tare Weight	2575 kg	2755 kg	2935 kg	3250 kg	3600 kg	4000 kg	4250 kg

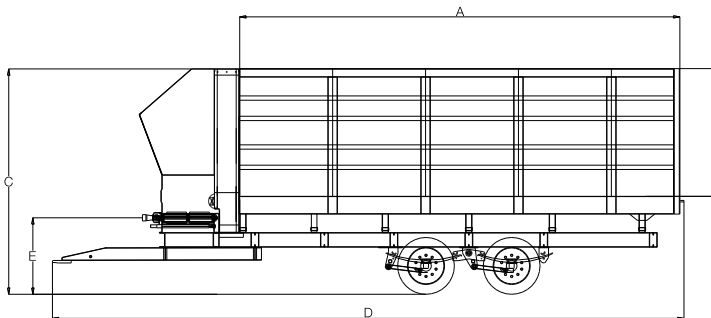

### OPTIONAL EQUIPMENT

- Lights £196
- Screw jack £379
- Rear discharge £1,473
- Hydraulic conveyor £162
- Hydraulic conveyor c/w spool block and flow control £676
- Weighing system £3,625

## FIELDRUNNERS

THE FIELDRUNNER RANGE OF HARVEST CHASER BINS.  
AVAILABLE IN 16, 20 & 24 TONNE MODELS.



Harvest Chaser Bins are designed to give maximum operating efficiency while minimising ground compaction by using low ground pressure tyres. The Fieldrunner has a high capacity chamber with a hydraulically driven longitudinal regulated auger feeding a high capacity PTO driven discharge auger. All machines run on tandem axles and the design means that the Fieldrunner has a low centre of gravity providing excellent stability when operating on sloping ground. All machines have roll over sheets, perspex windows, hydraulic brakes and RTA lights as standard.

## FIELDRUNNERS

FIELDRUNNERS	FR16	FR20	FR24
Price	£42,212	£48,442	£54,113
Overall Length	7.91 m	7.91 m	7.91 m
Overall Width (C)	3.00 m	3.00 m	3.00 m
Overall Height (Auger Extended) (D)	5.46 m	5.46 m	5.46 m
Overall Width (Auger Extended) (F)	3.58 m	3.58 m	3.58 m
Hopper Height (B)	3.70 m	3.87 m	4.07 m
Hopper Length (E)	6.50 m	6.50 m	6.50 m
Unloaded Height (G)	4.82 m	4.82 m	4.82 m
Number Of Axles	2	2	2
Axle Track	2.10 m	2.10 m	2.10 m
Tyres	710/50 x 26.5	800/40 x 26.5	800/40 x 26.5
Tare Weight	4000 kg	4350 kg	4700 kg

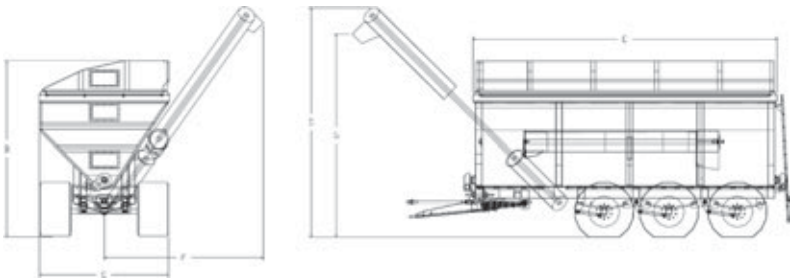

### STANDARD FEATURES

- Hydraulic driven horizontal auger
- Tandem axles and flotation tyres
- Roll over sheet
- Mesh grid
- Perspex windows
- Hydraulic brakes and lights

### OPTIONAL EQUIPMENT

- Reversing light kit           £227
- Internal light kit           £167

## TRANSFER WAGON



The Transfer Wagon is the ideal solution for transferring bulk crops, sugar beet, forage maize, wood chips etc., from harvesting machinery to road transport trailers.

Transfer wagons are designed to give maximum harvesting efficiency while minimising ground compaction by using low ground pressure tyres. The transfer wagon has a hydraulically driven chain and slat floor feeding a rear mounted discharge elevator. The rear elevator is interchangeable to suit the crop being harvested and unloading time is 2 – 4 minutes.

A high vision front grill and a twin camera kit allows the operator to see exactly how the machine is operating.

## TRANSFER WAGON

TRANSFER WAGON	BC18
Price	£62,769
Hopper Length	7.57 m
Hopper Top Rail Height	3.38 m
Loading Height	2.80 m
Overall Length	13.74 m
Overall Width	3.14 m
Maximum Unloading Height	4.83 m
Number Of Axles	2
Axle Track	2.30 m
Tyres	710/50 x 26.5
Tare Weight	8500 kg

### STANDARD FEATURES

- Sprung drawbar
- Flotation tyres
- On board PTO driven central hydraulic system
- Hydraulic brakes
- Road lights
- Electronic in cab control box
- Twin camera kit
- Hydraulically folding unloading elevator with adjustable discharge height
- High vision front grill panel

## DRILL FILLERS / MEAL AND PELLET FEEDERS

A RANGE OF HYDRAULICALLY DRIVEN DRILL FILLERS.  
AVAILABLE IN 6, 8 & 10 TONNE MODELS.



The Richard Western hydraulically driven drill filler has been designed as an economical means of transporting grain and fertiliser to drills and spreaders. The hydraulic motor can be controlled from the flexible spout on the end of the filling auger. The auger is raised and lowered by the means of a hand winch. To give access to the top of the hopper, a ladder and mesh grid are provided. A water-proof cover is also supplied.

### STANDARD FEATURES

- Hydraulic driven unloading auger
- Hydraulic brakes
- Parking brake
- Roll over waterproof cover
- Ladder and mesh grid

### OPTIONAL EQUIPMENT

- |                  |        |
|------------------|--------|
| ● Lights         | £196   |
| ● Centre divider | £1,224 |
| ● Screw jack     | £379   |

## DRILL FILLERS / MEAL AND PELLET FEEDERS

FILLER/FEEDERS	DF6	DF8	DF10
Price	£10,123	£11,659	£12,077
Body Length (A)	3.04 m	3.96 m	3.96 m
Body Width (C)	2.13 m	2.29 m	2.29 m
Top Rail Height (B)	2.59 m	2.90 m	3.10 m
Capacity	6 tonnes	8 tonnes	10 tonnes
Auger Outlet Height (D)	2.89 m	3.22 m	2.96 m
Number Of Axles	1	2	2
Axle Track	1.83 m	1.83 m	1.83 m
Tyres	400 x 15.5 14PR	400 x 15.5 14PR	400 x 15.5 14PR
Tare Weight	1900 kg	2500 kg	2750 kg

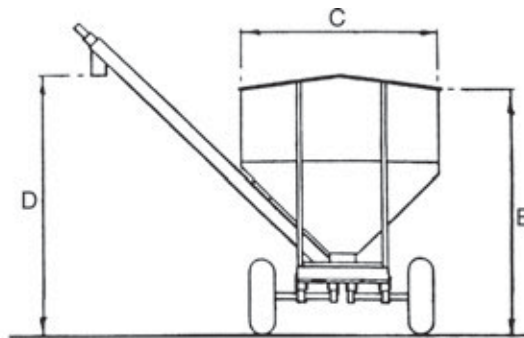
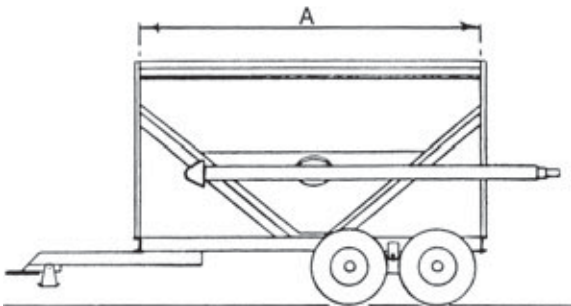

## OPTIONS

### REMOULD RADIAL TYRES

PRICE QUOTED IS PER WHEEL

Remould 15 x 22.5 in lieu of	12.5 x 15	£275
Remould 18 x 22.5 in lieu of	15 x 22.5	£323
Remould 20.5 x 22.5 Kargo Radial in lieu of	15 x 22.5	£547
445/45 x 19.5 Kargo Radial in lieu of	15 x 22.5	£323

### NEW CROSS-PLY TYRES

Vred 560/60 x 22.5 FP in lieu of	15 x 22.5	£556
----------------------------------	-----------	------

### NEW RADIAL TYRES

Vred. 560/60 x 22.5 FP in lieu of	15 x 22.5	£850
Vred. 560/45 x 22.5 FP in lieu of	15 x 22.5	£760
Vred. 650/50 x 22.5 FP in lieu of	15 x 22.5	£1,150
Vred. 710/40 x 22.5 FP in lieu of	15 x 22.5	£1,365
Vred. 620/55 x 26.5 in lieu of	560/50 x 22.5	£465
Vred. 710/50 x 26.5 in lieu of	560/50 x 22.5	£698
Vred. 800/40 x 26.5 in lieu of	560/50 x 22.5	£886

### MANURE SPREADER TYRE OPTIONS

23.1 x 26 tractor pattern in lieu of	18.4 x 34	£187
650/75 x 32 tractor pattern in lieu of	23.1 x 26	£644
710/50 x 30.5 flotation trac in lieu of	28.1 x 26	£1,275
750/60 x 30.5 flotation trac in lieu of	28.1 x 26	£1,536
580/70 x 38 tractor pattern in lieu of	650/75 x 32	£194
710/70 x 38 tractor pattern in lieu of	650/75 x 32	£1,103

OTHER TYRES OPTIONS ARE AVAILABLE ON REQUEST



Pic 3

Pic 2

Pic 4



Pic 1



1

2

3

## OPTIONS



### AXLE AND BRAKE OPTIONS

10 stud agri axle in lieu of	8 stud axle	£521
10 stud commercial axle in lieu of	10 stud agri axle	£1,560
Steering axle		£2,159
Air brakes with load sensing valves and hydraulic brakes		£1,768
ABS for air brakes		£1,683
Load sensing valves for hydraulic brakes		£625
Fail safe braking for hydraulic brakes		£673
*Fast tow pack air c/w ABS		£4,247
**Fast tow pack hydraulic brakes - no ABS		£2,094

### PAINT OPTIONS

Standard colour	Western Yellow	
Colours available:	JD Green, Case Red, MF Red, Ford Blue, Claas Green	£238
	Any other colour	£343
Two tone painting chassis/body or trailer/silage sides		£521

\* Fast tow pack includes: Air brakes with load sensing valves and hydraulic brakes, mudguards and mud flaps, LED flashing beacon, ABS braking)

\*\* Fast tow pack includes: Load sensing valves and Failsafe braking for hydraulic brakes, mudguards and mud flaps, LED flashing beacon)



## SPECIFICATION NOTES

### SPECIFICATION NOTES

Standard specification machines are designed to tow at speeds of 20mph.

LX models are designed to provide 50% braking at 60kph.

HS models are fitted with 10 stud commercial axles and 420mm x 180mm brakes.

"Fast tow pack" and ABS is recommended for all trailers travelling at speeds over 20mph.

LX and HS models are fitted with LED side marker lights as standard.

All rigid drawbar heights are designed for pick up/drawbars of 16" - 18" (420mm - 450mm)

All sprung drawbar options are adjustable for pick up/drawbars of 16" - 22" (420mm - 545mm)

Richard Western Ltd continues to make improvements to design and reserves the right to make changes to specification without prior notification.



## WARRANTY, TERMS & CONDITIONS

### WARRANTY

Richard Western Ltd manufactured equipment carries a one-year warranty from date of delivery. Any defect that applies to the workmanship of Richard Western Ltd will be repaired on site wherever possible, free of charge. If it is necessary for the machine to be returned to the factory the transport costs will be charged to the customer.

This warranty excludes all wearing parts and paintwork.

Parts that are not manufactured by Richard Western Ltd are covered by the manufacturer's guarantee and are subject to their Warranty. Their findings will be binding.

We will consider all claims during this period providing the following procedure is followed:

1. A completed Warranty Registration Form has been returned to us.
2. We are notified immediately of any defect.
3. No work is carried out without obtaining Warranty Authorisation.
4. Richard Western Parts are used for any repair work.

### TERMS & CONDITIONS

All items in this price list are sold under our 'Terms and conditions of Sale'. Copies are available on request.

Prices of all goods are those ruling at the date of despatch and we reserve the right to change prices without notice. All dimensions and specifications quoted in this list are for guidance only. In line with our policy of continuous improvements, we reserve the right to amend specifications without prior notice or obligation to existing equipment.

Orders under £8500 value will be subject to a delivery charge.

**TRAILERS • MANURE SPREADERS • VACUUM TANKERS**

**FORAGE FEEDERS • CHASER BINS • GRAIN AND FERTILISER HANDLING**

**RICHARD WESTERN LTD**

D'Urbans, Framlingham, Suffolk IP13 9RP

**TEL: 01728 723224**

**SALES MANAGER: 07771 818461 (mobile)**

**FAX: 01728 724291 EMAIL: [sales@richard-western.co.uk](mailto:sales@richard-western.co.uk)**

**WEB: [www.richard-western.co.uk](http://www.richard-western.co.uk)**